

# MANISCOPIC

# ■ MT-X 1740 SLT





- Maximum lifting height : 16.65 m
- Nominal capacity :  
4000 kg at 500 mm
- Maximum forward reach : 12.35 m
- Torque convertor
- 4 wheel drive - 4 wheel steer
- Hydraulic stabilizers
- Frame levelling

 **MANITOU**

Courtesy of Crane.Market

# MT-X 1740 SLT

 **Lift capacity** .....4000 kg  
 at 500 mm from forks heels.  
 Tipping load at maximum reach  
 with stabilizers .....957 kg  
 Tear out force with bucket  
 as per ISO 8313 .....7000 daN

 **Lift height** .....16.65 m  
**Times** : unladen / loaded (in s)  
 Lifting .....15/16  
 Lowering .....10/9  
 Extension 1<sup>st</sup> and 2<sup>nd</sup> booms .....21.8/24.4  
 Extension 3rd boom (with stabilisers only) ..10.4/11.5  
 Retraction 1<sup>st</sup> and 2<sup>nd</sup> booms .....17.7/17.4  
 Retraction 3rd boom (with stabilisers only) ....9.7/8.7  
 Time unladen (in s)  
 Crowd .....5.3  
 Dump .....8.4

 **Tyres**  
 440/80-24 BAT

 **Forks** (mm)  
 Length .....1200  
 Width x thickness .....125 x 50  
 Maximum distance between forks .....1040  
 Carriage rotation .....124°

 **Multidisc brakes - hydraulically assisted on both axles**

 **PERKINS Engine Turbo**  
 Type .....1104D- 44TA  
 Capacity .....4 cylindres 4400 cm<sup>3</sup>  
 Power (ISO/TR 14396) :  
 at 2200 tr/mn .....101 HP/74.5 kw  
 Maximum torque (ISO/TR 14396) ..412 Nm at 1400 r.p.m.  
 Direct Injection  
 Water Cooling

 **Transmission** .....Torque convertor  
 Electro-hydraulic reversing shift  
 4 gears forward and reverse  
 Maximum travel speed .....25 km/h

 **Hydraulics**  
 Gear type .....260 bars/196 l/mn  
 Flow divider with priority to steering and brakes

 **Capacities**  
 Cooling system .....18.5 l.  
 Engine oil .....11 l.  
 Hydraulic oil .....175 l.  
 Transmission oil .....16 l.  
 Fuel tank .....135 l.

 **Weight unladen** (with forks) .....11220 kg  
**Overall width** .....2.42 m  
**Overall height** .....2.60 m  
**Turning radius** (outside wheels) .....4.17 m  
**Overall length** .....5.98 m  
**Ground clearance** .....0.48 m  
**Drawbar pull** (unladen) .....9700 daN

Under  
 EN 1459  
 annexe B

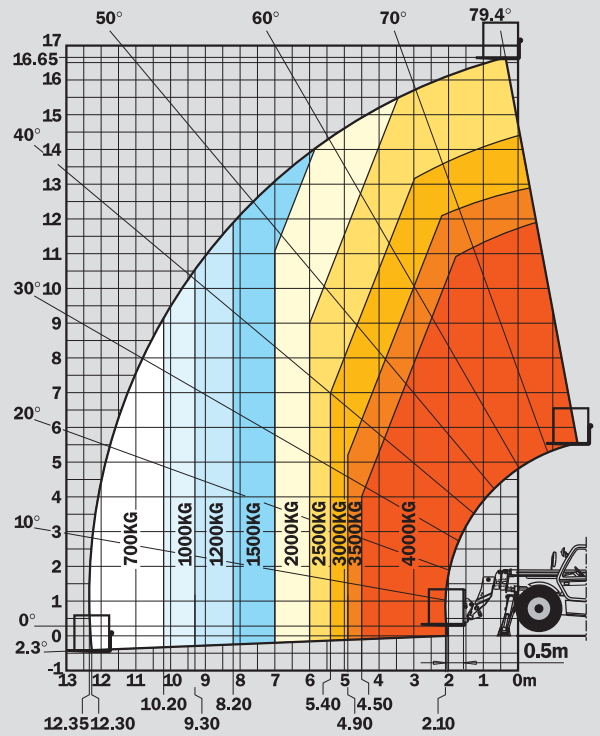

A	1200
B	2770
C	2160
C1	2232
D	5980
D1	6052
D2	4435
E	7180
F	1990
F1	1990
G	480
G1	475
G2	480
G3	290
H	7°
H1	7°
I	1050
J	950
K	1040
L	50
N	1880
O	125
P2	45,5°
P3	50°
R	3950
S	8912
T	4239
U1	2605
U2	2785
V	5709
V1	1470
V2	4168
W	2425
W1	3820
W2	1050
W3	2350
Y	12°
Z	112°

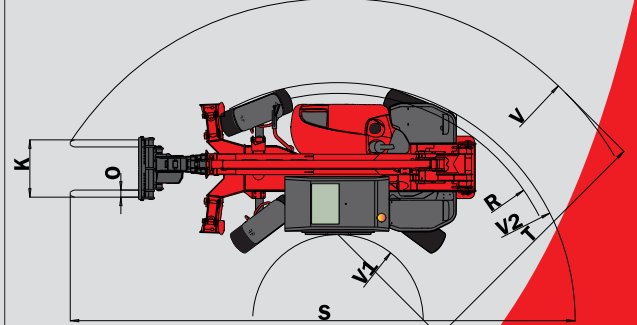
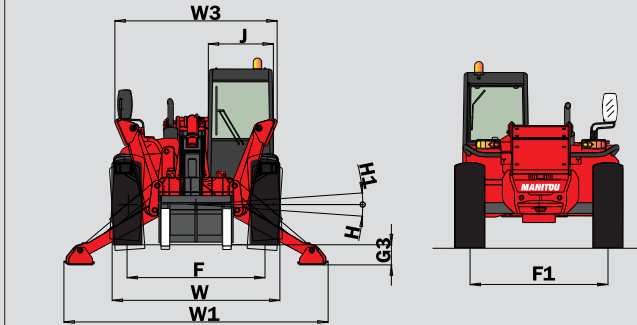
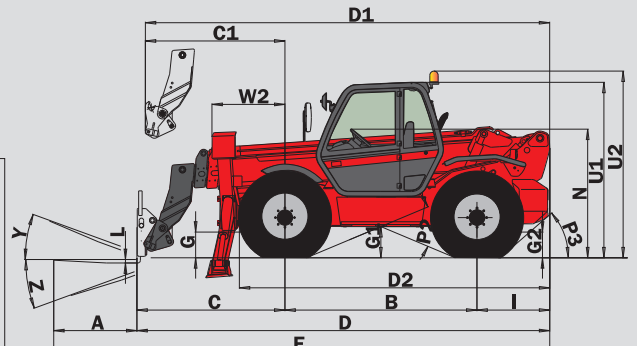

This equipment described in this leaflet may be standard, optional, or unavailable, depending on the versions. For more details, contact your MANITOU dealer.

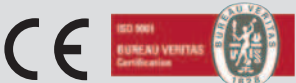

**MANITOU BF SA**  
 B.P. 249 - 44158 Ancenis Cedex - France  
 Tel. : 33 2 40 09 10 11 / Export Department Fax : 33 2 40 09 10 97  
 www.manitou.com



Courtesy of Crane.Market